

OUTLINE DRAWING:

REV	DESCRIPTION	DRAWN BY	APPROVED BY	DATE
A	FIRST ISSUES	FAN		04-11-2021

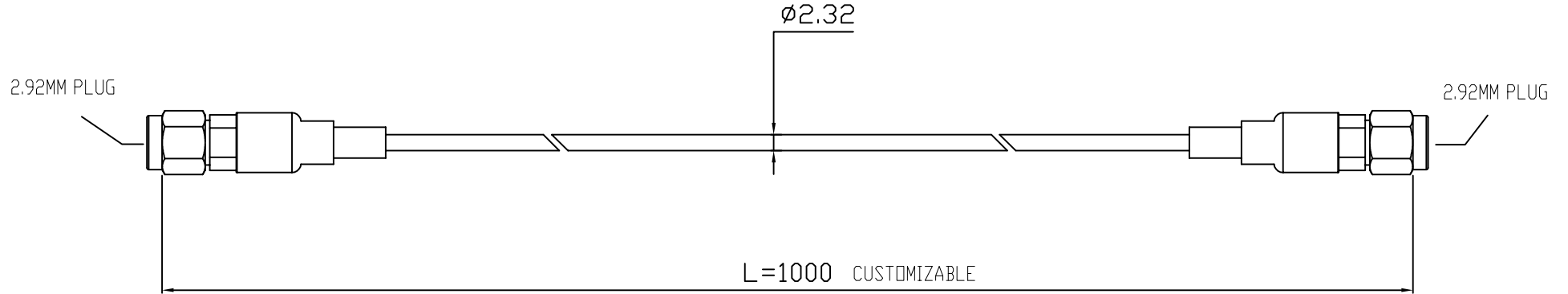

NOTE:

- 1.IMPEDANCE: 50±0.5 OHM
- 2.FREQUENCY RANGE: DC~40GHz
- 3.VSWR: 1.2 MAX
- 4.DWV: 500 VRMS MIN
- 5.OPERATING TEMP: -40~+125°C

BODY	STAINLESS STEEL	PASSIVATED
DIELETRIC	ULTEM	NATURAL
CENTER CONTACT	BECU	GOLD
DESCRIPTION	MATERIAL	FINISH

DIMENSION: MM	SERIES: 2.92MM	CABLE: XFWP-90	DesignCon	
General tolerance Unless otherwise specified 0 Plance: ±0.2 1 Plance: ±0.2 2 Plance: ±0.2	PRODUCT Spec:	ASSEMBLY INSTR		
Angles:	DRAWN:	FAN	04-11-2021	PART NUM:
	CHECKED:	FAN	04-11-2021	DRAWING NUM:
	APPROVED:			SCALE: 2:1
	CUSTOMER DRAWING			REMARK:
	This drawing is a controlled document			PAGE: 1/1